

3P HYDROSYSTEM[®] VORTEX FILTER MANUAL

For Installation, Operation & Maintenance
in Concrete Manholes & Vaults

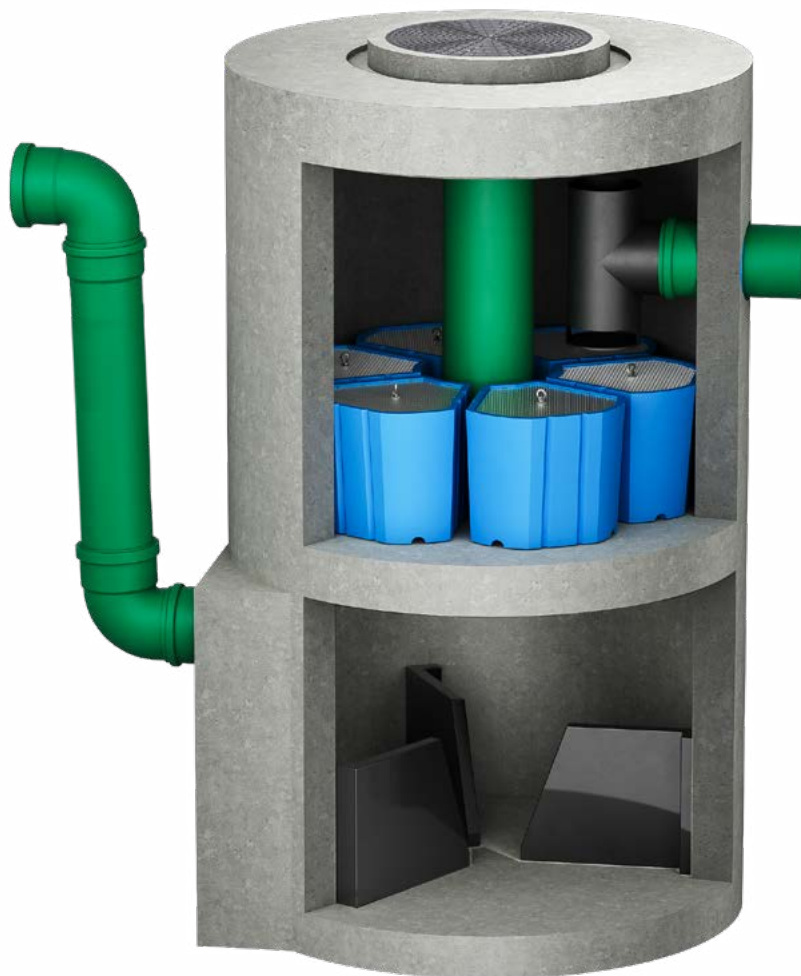

1. Introduction
2. Product Delivery and Inspection
3. Handling and Lifting the Hydrosystem Vortex Filter and Filter Cartridges
4. Preparing the Excavation and Manhole or Vault
5. Installing a Hydrosystem Vortex Filter in a Manhole or Filter Cartridges in a Vault
6. Inspection, Maintenance and Cleaning

HOW THE HYDROSYSTEM® VORTEX FILTER WORKS

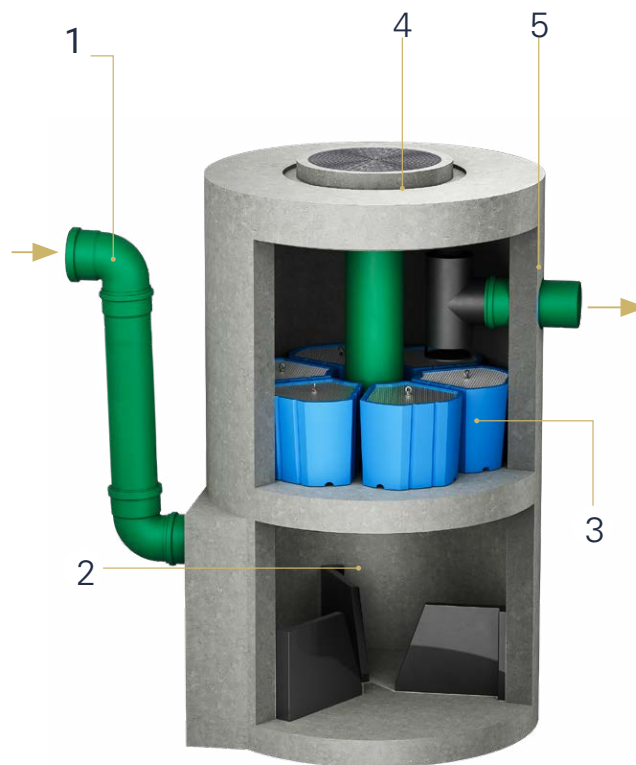

IMAGE 1

1. The stormwater feeds into the lower end of the filter housing, or the bottom of the manhole or tank. The angled inlet pipe generates a radial flow pattern.
2. The hydrodynamic separator shifts turbulent stormwater into a radial laminar flow, which generates particle sedimentation.
3. The larger particles settle at the bottom of the housing, manhole or tank. Suspended and settled solids are periodically cleaned out.
4. In the central section of the unit, the Filter Cartridges filter out fine particles in an upward flow process. The majority of dissolved pollutants are precipitated and adsorbed.
5. The Filter Cartridges can be flushed from street level and, when needed, are easily exchanged. The cartridges are easily removed (with lifting eyes) through the access opening.
6. The clean water (above the filter elements) passes through an oil separator and flows through the outlet pipe into the groundwater or surface water.

EASY INSTALLATION STEPS

1. Install flow breakers (manhole only)
2. Connect Inlet piping
3. Install Filters
4. Install Internal Piping
5. Connect Outlet Piping

**NOTE TO CONTRACTING INSTALLER:**

Before beginning the installation, read through this entire document. Keep this document at the work site to refer to safety procedures as needed. It is the contractor's responsibility to ensure that all the correct piping components required by product and site drawings have been ordered and are at the site before installation begins.

SECTION 1: INTRODUCTION

1. These instructions relate to installing, operating and maintaining the Hydrosystem and Filter Cartridges.
 2. Compliance with this manual is necessary for the proper handling, installation, maintenance, inspection and operation of these products.
 3. It is the responsibility of the project owner and the installing contractor performing the installation to understand and follow all requirements contained in this document (the edition in effect at the time of installation), and to comply with all federal, state or provincial, and local safety regulations that apply.
- NOTE:** The presence of our representative does not relieve the installer of having sole responsibility for proper installation.
4. No instructions or procedures presented in this manual should be interpreted so as to put at risk any person's health or safety, or to harm any property or the environment.
 5. Work must be performed according to standard industry practices applicable to this installation and product operation.
 6. Work must comply with all relevant codes, regulations and standards of appropriate governmental agencies, such as:
 - construction, health, safety and environmental codes
 - industry standard practices
 - confined space entry
 7. Governmental agency codes, regulations and standards always take precedence over our requirements.
 8. Any variation to, or deviation from, these instructions must be approved in writing from us prior to installation.
 9. Failure to comply with this document will void our obligations under the applicable limited warranty.

10. If project requirements exceed any of our requirements, the project engineer must consult with our engineers by contacting us at **contact@3ptechnik.com** for approval.

11. For questions regarding the interpretation of these instructions or for any other technical inquiries, contact us at **contact@3ptechnik.com**

SECTION 2: PRODUCT DELIVERY AND INSPECTION

12. Check the delivery against the project order. If any components are missing, contact your sales representative.

13. Every Hydrosystem for a manhole includes the following components (See IMAGE 1.):

- Filter cartridges
- Gaskets
- Flow breakers

14. Filter Cartridges for a vault includes the following:

- Filter Cartridges
- Gaskets

NOTE: For both manholes and vaults, piping and anchors will be supplied either by us, the contractor or the precaster.

15. Visually inspect the Hydrosystem – both the interior and exterior – and/or the Filter Cartridges to make sure that no shipping or handling damage has occurred. Look particularly for visible damage, cracks or deep scrapes.

NOTE: Do not attempt any repairs. If damage is detected, contact your sales representative.

SECTION 3: HANDLING AND LIFTING THE HYDROSYSTEM AND FILTER CARTRIDGES

NOTE: Protect the filters from dirt and debris at all times. Store and install filters and gaskets at temperatures between 40-110° F / 4-44° C.

16. Before unloading the Hydrosystem and Filter Cartridges when they are delivered, select a smooth, solid, level area on which to place them, and clear that area of all large rocks, trash and debris.

Notice

The installer must take care so that the Hydrosystem or Filter Cartridges are not rolled, dropped or damaged during loading, unloading, handling and installing as this could result in damage to the product.

17. Use the lifting lug on top of each Filter Cartridge when handling it. See **IMAGE 2**.

NOTE: Each Filter Cartridge weighs about 150 pounds.



⚠ CAUTION

While moving or lifting the Hydrosystem or Filter Cartridges, do not position any part of your body underneath it. Failure to follow this caution could result in minor or moderate injury.

SECTION 4: PREPARING THE EXCAVATION AND THE MANHOLE OR VAULT

⚠ CAUTION

Working in and around excavations is dangerous. Follow all OSHA and/or Canadian regulations related to excavations. Collapse of excavation walls could result in death or serious injury.

⚠ WARNING

Careless activity or reckless operation of equipment can cause death, serious injury or property damage.

- 18. Locate the excavation location according to the project's site plan.
- 19. Prepare the excavation according to the site requirements and standard industry practices.
- 20. Make sure excavation walls are supported according to applicable industry and regulatory requirements.
- 21. Install the concrete manhole or vault according to its manufacturer's instructions.
- 22. Before installing the manhole or vault, make sure that the piping openings, such as bypass and internal piping, weirs and baffles correspond to the product and/or system drawings.

NOTE: The bottom of the outlet pipe tee must be at least 10 inches above the top of the Filter Cartridge.

SECTION 5: INSTALLING A HYDROSYSTEM IN MANHOLE OR FILTER CARTRIDGES IN VAULT

NOTE: Protect the filters from dirt and debris during installation.

- 23. In a manhole installation, install the flow breakers. The flow breakers are to be spaced at 120 degrees from each other. Each flow breaker has 3 predrilled holes. Attach the flow breakers to the wall of the manhole, with a 3/8"-diameter concrete anchor. See **IMAGE 3**.



- 24. In manhole installations, connect the inlet piping and make sure the 90-degree elbow of the piping inside the manhole is oriented in a horizontal (not vertical) plane.
- 25. For a vault installation follow the shop drawings, typically there is not a horizontal interior bend for the inlet pipe.
- 26. Seal the inlet connection with non-shrink grout or other industry-standard watertight connection.
- 27. The inlet should be just above the flow breakers. Seal the connection by applying non-shrink grout or another industry-standard watertight seal.

NOTE: Alternatively, the engineer may recommend using a watertight connection.

NOTE: Be sure the piping joint is tightly sealed.

- 28. In a manhole installation, place the top section of the manhole on the bottom section. The top section will have the filter platform.
- 29. Install the gaskets into the preformed holes on the filter platform in the manhole or vault platform according to the product and/or system drawings. See **IMAGE 4**.

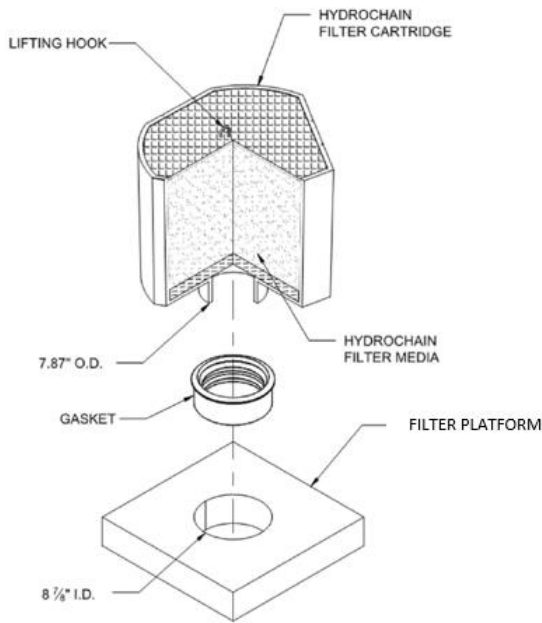

IMAGE 4

30. Make sure the gasket lip is on the top of the preformed hole.

31. When the filters are placed in a circular configuration, place the gasket for the center pipe now. The center pipe gasket size will be called out on the shop drawing and is not included when the Hydrosystem or Filter Cartridges are shipped.

NOTE: Each new Filter Cartridge weighs approximately 150 lbs.

32. Install Filter Cartridges by lowering each one into the structure with a davit crane connected to the filter's lifting ring. See **IMAGE 5**.



IMAGE 5

NOTE: The Filter Cartridges are held in place by their own weight. No anchors are needed. Check to make sure the Filter Cartridges are level.

33. When all Filter Cartridges have been installed, insert the outlet pipe tee.

NOTE: So the filters don't become clogged during installation, we recommend covering them at all times to protect them from dirt, joint sealer and mortar, etc. This will eliminate the need to clean or replace them.

34. Push the outlet pipe tee through the outlet opening. Seal the connection with non-shrink grout or other industry-standard watertight seal.

NOTE: Alternatively, the engineer may recommend using a watertight connection instead.

NOTE: Be sure the piping joint is tightly sealed.

35. Use a pipe ring, connecting dowel and anchor plate (provided by others) to secure the pipe tee to the interior of the concrete manhole or vault.

NOTE: We recommend installing the pipe ring on the upper portion of the pipe tee. This will allow for easy removal during maintenance.

36. If outlet piping is completed now, complete the connection to the storm sewer, which can be done with a coupler.

37. Install bypass and internal piping per the product and/or system drawings.

NOTE: The bottom of the site invert piping must be at least 10 inches above the bottom of the outlet piping.

38. In a manhole installation, complete the inlet piping on the outside of the manhole.

- Connect appropriate pipe elbows on the outside of the manhole inlet connection so the piping orientation is vertical.
- Extend the vertical inlet pipe to the required top height per site plans and install the final pipe bend so it is in the horizontal position when connected to the existing storm sewer.
- Connect the vertical inlet piping to the exterior manhole or vault with the anchor and pipe ring (provided by others).

NOTE: The connection to the storm sewer can be made with a coupler.

39. In a vault installation, complete the inlet piping connection to storm sewer per site and product and/or system drawings.
40. If the outlet piping connection to storm sewer has not been completed, do that now.
41. Continue assembling the manhole or vault.
42. Backfill the excavation hole according to project specifications.

SECTION 6: INSPECTION, MAINTENANCE AND CLEANING

NOTE: Inspecting, maintaining and cleaning Vortex Filters in a manhole and Filter Cartridges in a vault generally do not involve confined space entry. Consult system product and/or system drawings to determine whether entry is necessary. If entering a manhole or vault is required, follow applicable OSHA and Canadian regulations related to confined space entry. Failure to follow this warning could result in death or serious injury.

GENERAL

43. The owner is responsible for determining the inspection and maintenance schedule.

NOTE: Refer to the project drawings for the system's vault or manhole configuration when establishing an inspection and maintenance schedule. Contact the design engineer to obtain drawings.

44. We also recommend that the site owner establish an inspection and maintenance schedule based on the following factors:

- Manhole or vault size
- Site and environmental conditions
- Drainage area
- Annual rainfall
- Volume of stormwater runoff
- Volume of sediment, dirt, debris and trash entering the system
- Volume and type of pollutants collected

45. We recommend that following installation, the system be inspected a minimum of every 6 months. To ensure that the system is functioning as designed, we recommend inspecting the system immediately after the first major rainfall or storm event following installation. Inspection may then be increased or decreased based on the project drawings and the factors listed above.

46. We recommend that the system be cleaned at regular intervals. Typically, the manhole or vault structure is emptied of sludge every three to six years. Cleaning may be required more or less frequently depending on the factors listed above.

NOTE: Filters can be functional up to 10 years from initial installation if properly flushed and maintained. Depending on the volume of sediment and pollutants, filters need to be flushed (or replaced) every 3 to 6 years. We recommend flushing filters no more than twice.

47. The site owner is responsible for creating, recording and retaining inspection and maintenance records in accordance with their own site requirements and applicable regulations. The log at the end of this manual is provided only as an example.

NOTE: Proper and optimum operation of the Hydrosystem and Filter Cartridges requires following these recommended inspection, maintenance and cleaning guidelines.

NOTE: Exceeding the recommended maximum volume of suspended solids and hydrocarbons will jeopardize the effectiveness of the filters.

INSPECTION PROCEDURE

48. Visually inspect the Hydrosystem or Filter

Cartridges at each access point. See **IMAGE 1** for example of manhole configuration. See **IMAGE 6** for example of vault configuration.

IMAGE 6



49. Remove the access cover and record the inspection location.
50. Visually inspect for floating waste to determine if maintenance is required.
51. If there is floating waste, remove it.
52. Visually inspect the bypass system, such as bypass and internal piping, weirs and baffles.
53. If the water level rises above the center bypass pipe, it indicates that the system is clogged, and maintenance and/or cleaning of the filters and/or manhole is required.

- 54. Sediment visibly accumulating on top of the Filter Cartridges is also an indication that the system is clogged and cleaning of the filters and/or manhole is required.
- 55. A sheen of free oil floating above the filters indicates a possible oil spill, for which maintenance is required.

NOTE: If the system is inspected when there are no flows, unless the filters are completely clogged the height of the water level will be the same across the bypass pipe and outlet. This should not be considered a definitive sign that the system is fully functioning, and periodic maintenance is still required to maintain system performance.

* +#] d'YZiZϕ cZ'i] Z'z̄kZād['hiVcYc\`1 ViZgVcY` VXXj b j á/iZY`hZYb Zci!['dæd\`i] h'egdXZYj q̄/

- Measure the distance between the top of the access riser to the top of the hiVcYc\`1 ViZg# This is measurement #1.
- Measure the distance between the top of the access riser to the top of the sediment in the lower chamber. This is measurement #2.
- Measure the distance between the top of the access riser and the floor of the manhole or vault. This is the measurement #3.

NOTE: One method to determine measurements #2 and #3 is to lower a stadia rod towards the bottom of the manhole or vault until resistance is encountered. If sediment has collected, this is the top of the collected sediment (#2). Push the stadia rod through the sediment to the manhole or vault floor (#3).

- 57. Subtract measurement #2 from #3. If the value is greater than 20 inches, it indicates that maintenance and/or cleaning of the manhole or vault is required.
- 58. Replace the access cover.
- 59. Record recommended or required maintenance on the inspection and maintenance log (provided by site owner).

MAINTENANCE AND CLEANING PROCEDURES NOTE: We recommend using a pump-out vehicle equipped with suction and flushing capabilities, or a submersible sediment (sludge) pump with hoses, such as a hydrovac truck. A truck with sufficient storage capacity is necessary in order to remove floatables, standing water and sediment.

NOTE: For a vault installation, a separate truck may be required to remove the standing water before cleaning.

- 60. Before beginning maintenance and cleaning, review the inspection record to see recommended or required maintenance, and the amount of standing water and sediment to be removed.

- 61. Determine the standing water volume to be removed.

NOTE: In a vault installation, use the following formula to determine the volume:

- In U.S. installations, standing water volume in gallons = vault width (feet) x vault length (feet) x standing water depth (feet) x 7.48 (this equals XX cubic feet)
- In Canadian installations, standing water volume in liters = vault width (meters) x vault length (meters) x standing water depth (meters) x 1000 (this equals xx cubic meters).

- 62. Determine the equipment needed for maintenance and cleaning.

- 63. If the filters are to be cleaned onsite:

- Place a flushing washtub close to the manhole or vault excavation.
- Prepare a clean protected area to hold the cleaned cartridges before re-installation.

NOTE: Flushing washtubs can be purchased by contacting us at contact@3ptechnik.com. See **IMAGE 7**.



- 64. To begin maintenance and cleaning, remove each access cover.

- 65. Suction out the water in the manhole or vault until the water level is below the filter platform. When the filters need to be cleaned, this allows them to drain (and be lighter in weight) for easier removal. See **IMAGE 8**.



66. To remove the accumulated sediment from the bottom of the chamber, insert a suction hose in the bypass piping and suction out all sediment and remaining water from below the filter platform. See **IMAGE 9**.

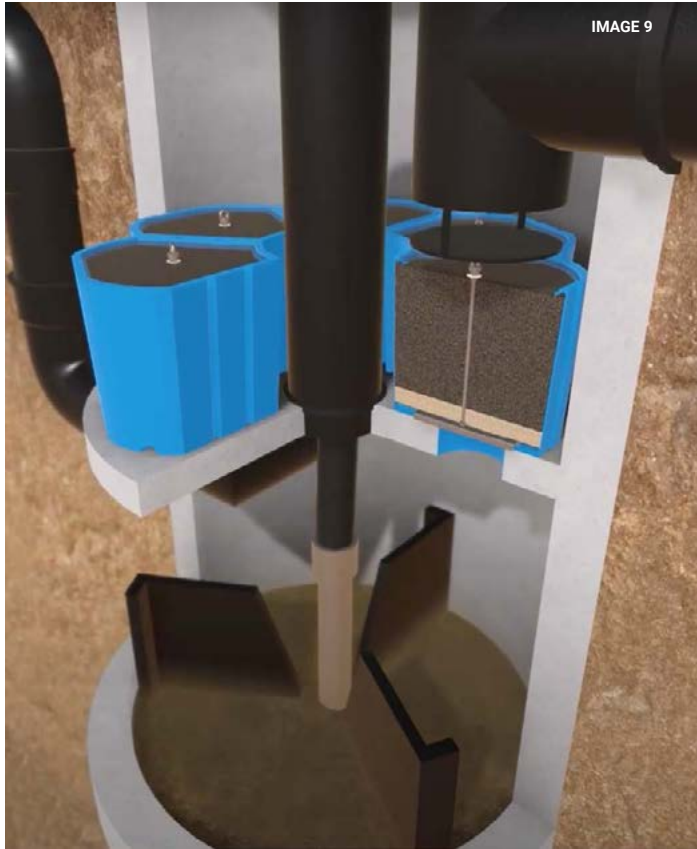

67. If cleaning of the manhole/vault or flushing of the filters is required in addition to removing the accumulated sediment, remove each filter with a davit crane connected to the filter's lifting ring. If undamaged, the filter gaskets may be reused. If damaged, purchase new gaskets by contacting us at **contact@3ptechnik.com**.

NOTE: Each filter weighs approximately 200 pounds when saturated with trapped pollutants.

68. To clean the chamber after removing the filters, use a hose with a spray nozzle to power wash the walls and floors of the manhole or vault above and below the filter platform. Water accumulating during the cleaning process may need to be removed periodically before the entire chamber is cleaned.

NOTE: For vaults, we recommend using a nozzle with a 36-42" spray width and pressure of 1000-2000 psi.

69. To clean filters onsite, install saturated filters into the flushing washtub and prime the washtub with water and pressurized air.

70. Flush the filters in the washtub with alternately cycles of water and air, releasing solids and oils upward out of the filter media. Repeat this process until the water flushed through the filter appears clear, which typically takes 5-15 minutes. See **IMAGE 10** (on the left: sediment being flushed out, on the right: oil being flushed out).

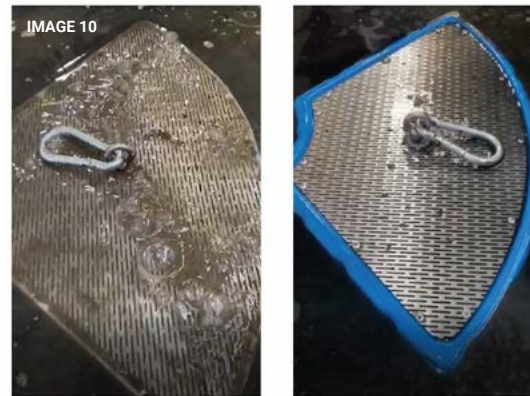

71. Drain the flushing washtub of entrained water and remove the flushed filter, placing it in a clean, protected area free of sediment and debris until it can be reinstalled in the filter plate.

NOTE: Dispose of the pollutants per applicable regulations.

72. Repeat the flushing process for each saturated filter.

73. When the filters have been flushed and the manhole or vault has been cleared of sediment and cleaned, reinstall the filters with the proper orientation and gaskets following the installation instructions above.

NOTE: There is no manifold system below the filters, simply reinsert them into their existing orifices, making sure the gasket is still in place.



- 74.** Once the cartridges are reinstalled, reinstall any remaining piping (for example, the outlet pipe tee).
- 75.** Close and lock the access covers.
- 76.** Dispose of all removed water and waste material in accordance with applicable regulations.
- 77.** Record details of maintenance performed in the inspection, maintenance and cleaning log provided by the site owner.

SAMPLE INSPECTION AND MAINTENANCE RECORDS LOG

SITE DATA

Site Owner	
Site Address	
Type of Treatment	
Product Number and Order Number	
Type of Installation (Manhole or Vault)	
Installing Contractor	
Installation Date(s)	

INSPECTION AND MAINTENANCE LOG

Inspection or Maintenance Specify					
Date of Inspection or Maintenance					
Name of Inspector or Maintenance Contractor					
Standing Water Record Volume					
Visible Oil Yes or No					
Oil Removed Yes or No					
Floatable Debris Yes or No					
Floatables Removed Yes or No					
Sediment Record Depth					
Sediment Removed Yes or No					
Recommend that Filters Be Cleaned or Replaced Yes or No					
Were Filters Cleaned? Yes or No					
Were Filters Relaced? Yes or No					

NOTE: Consult appropriate regulatory agency for information on disposal of pumped-out water and waste material.

3P Technik Filtersysteme GmbH

Robert-Bosch-Straße 16-18
73337 Bad Überkingen
Deutschland

T +49 (0) 7334-92460-0

info@3ptechnik.de
www.3ptechnik.de

